

RB ROCK BOWL

RockBowl Rules 2022

Organization



Support



Safety is our nature

1. General Rules and Regulations

1.1. Eligibility

- a. The competition is open to undergraduate and graduate students (MSc and PhD), ISRM members, from any university.
- b. All interested teams must submit all completed registration documents to the organizing committee of the event before June 30, 2022.
- c. There is no cost to participate in the RockBowl.
- d. The participating teams are responsible for costs associated with travel to the IX LARMS Congress 2022. Participant students will be funded by the congress organization with the registration to the IX LARMS Congress 2022, accommodation during the congress and food vouchers.

1.2. Communication

- a. All communication and disclosure rules before and during the game will be held exclusively in English.
- b. Any clarification regarding RockBowl rules must be requested by email by July 30, 2022 at the following e-mail address: rockbowl.larms22@gmail.com
- c. Follow announcements and news about the competition in a dedicate RockBowl page on the IX LARMS 2022 website: <http://www.larms2022.com>

1.3. Awards

- a. Prizes will be awarded exclusively to the winning participants. Awards for the winning team participants are going to be announced before June 30, 2022.
- b. The participant with the best performance in the competition will also receive an award. The award for the participant with the best performance is going to be announced before June 30, 2022.

2. Changes in the rules

- a. The competition rules are subject to changes that may be necessary, if approved by the organizing committee of the game.
- b. The organizing committee has the right to cancel the competition at any time until the day August 14, 2022.
- c. Any changes in the rules, clarifications, additions and / or game cancellation will be announced:
 1. Via e-mail to all participating teams;
 2. On the RockBowl webpage.
 3. At the opening of the competition.

3. Registration Guidelines

- a. Call for participation in RockBowl will be announced by the ISRM National Groups, on the ISRM website and on the IX LARMS 2022 Congress website. If you are interested in participating, the team should contact by e-mail with the Organizing Committee, through rockbowl.larms22@gmail.com.
- b. During the registration period, the organizing committee of RockBowl will contact teams by e-mail.
- c. The registration form will be available online on the RockBowl webpage at the time of opening of registration.
- d. All team members must be from the same university. Members from different campuses will be accepted as long as they are from the same university. In exceptional cases, a country team with students from different universities can be accepted upon organizing committee evaluation.
- e. Application should be filled out and document files uploaded through RockBowl online or pdf registration forms. Documents required are listed below:
 1. Application form duly completed by all participants of the team;
 2. Proof of enrollment at University (the current semester or year) of all participants of the team;
 3. Face photo of each participant (3x4 ratio);
 4. Questionnaire Form completed.
- f. In order to assure the team registration, professor tutor should send an e-mail (institutional e-mail) informing his/her name and university as well as the name of team members.
- g. The selected teams will be published on the RockBowl webpage at the end of the registration period.
- h. Teams that do not comply with all the rules mentioned in this item will be automatically disqualified.

4. Qualification

- a. Eight (8) teams will qualify to participate in the tournament.
- b. The qualification will occur respecting the order in which online registration took place. If two or more teams from the same university / country enroll, the first to sign up is automatically qualified and the others will be held in stand-by.
- c. The availability of vacancies in the competition for the teams in the line may occur in case of withdrawal of some previously qualified teams, or if there are not eight (8) teams automatically qualified according to the item 4.b.
- d. If there are more than eight (8) teams registered, the qualification will occur according

RockBowl IX LARMS 2022

to item 4.b. until all the remaining teams come from the same country or all spots are filled. If the remaining teams come from the same country and the number of teams selected is less than eight (8), a qualifying game with those teams will be done prior competition to fulfill the vacant spots.

5. Important Dates

- a. The final date of the application period will be June 30, 2022.
- b. The announcement of the selected teams will be on July 19, 2022.
- c. Cancellations should be informed until July 12, 2022, allowing the call for new teams from the waiting list as well as adjustment of rounds.
- d. The games will take place from October 16 to October 19, 2022, at the Conmebol Convention Center and Bourbon Asunción Hotel, Asunción, Paraguay.

6. Rules of Competition

6.1. Game format and general rules for the competition

- a. Eight (8) teams may enroll, as set out in item 4 of this regulation. The system of competition in the game is by simple elimination, or a team is eliminated in each match.
- b. If the number of registered teams is less (or more) than eight (8), adjustments to the rules will be made and released by amending the regulation.
- c. Definition of rounds: the pairs of opposing teams in each round of the qualifying round will be drawn by lot, to be held in the presence of the teams.
- d. In case of non-attendance of a team at the date and time of the draw of team groups, the team will be disqualified and removed from the competition grid and the remaining teams will be adjusted.
- e. If a team does not attend the game after the draw of the team groups, the opposing team moves to the next phase automatically.
- f. The draw for the sets of questions for each round will be held at the beginning of each game.
- g. If more than eight (8) teams are registered according to item 4.d, a qualifying game will take place prior the competition. The qualifying will follow the rockbowl general rules with eliminatory games. If the number of winning teams do not exactly match the number of vacant spots, the selection will follow from the eliminated teams that scored more points until all spots are filled. In case of a tie, the order of registration will be the tiebreaker.
- h. The scheme of the team groups is illustrated in Figure 1. The conceived arrangement of teams, moderator, judges and officials of the game (control), as well as display devices for teams and audience, can be seen in Figure 2.

RockBowl IX LARMS 2022

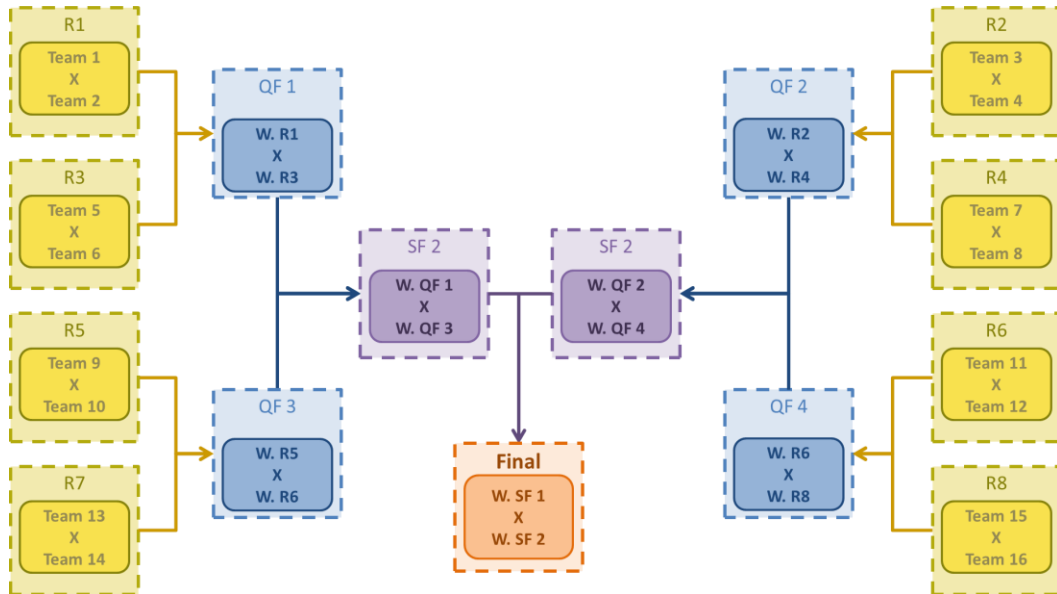

Figure 1. Configuration of team groups of the RockBowl IX LARMS 2022 (R: round, QF: quarter final, SF: semifinal and W: Winner).

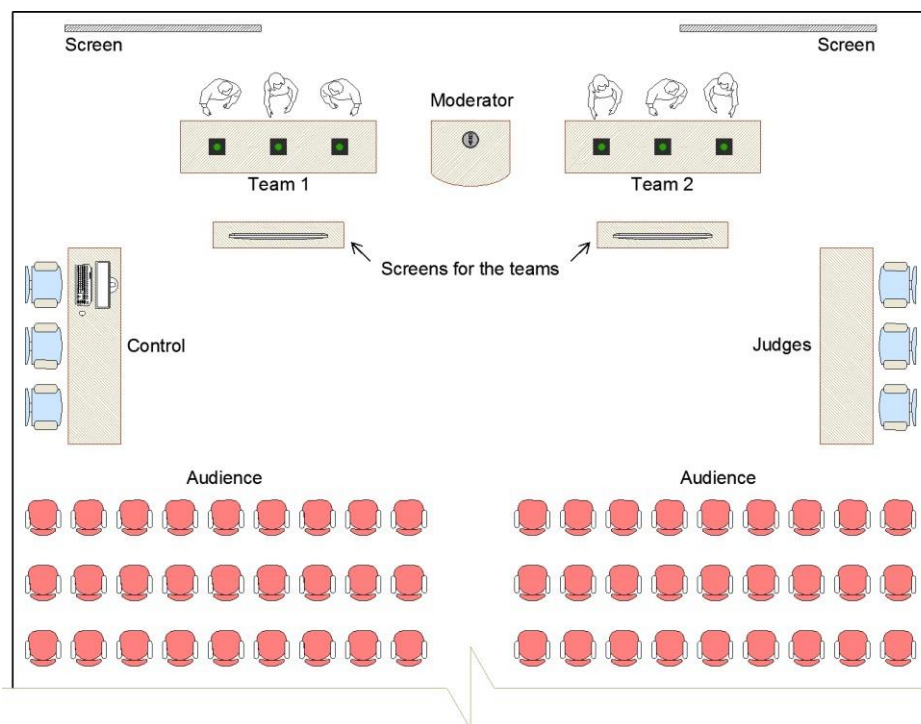

Figure 2. Idealized arrangement of RockBowl IX LARMS 2022 environment.

6.2. Tournament officials

- a. Judges: each dispute shall have three (3) judges with no links with the applied teams. All decisions made by the judges will be considered as final decisions.
- b. Moderator: the moderator reads the questions, consult the judges when necessary to assess whether the answers are correct, grants and deducts points, and strengthens the rules of the competition.
- c. Game inspector: there will be a game inspector for each team during each round in order to ensure that the rules are complied with, and any violations are reported by the moderator.

6.3. Equipment

- a. In every game, each player will have a buzzer in front, which consists of an electronic device installed on the counter with the task of determining which player pressed first the button to answer the question.
 1. Each participant is responsible for verifying the operation of his/her buzzer during the game;
 2. If a buzzer presents problems, only the general current question or the last general question can be repeated, subject to moderator analysis if the malfunction impacted the game at that point.
- b. The game time will be controlled by a chronometer clearly visible by both teams.
- c. Calculators, reference materials, and any electronic devices are not allowed. There will be no questions involving calculations.
- d. The points count per team as well as individual player, will be performed automatically by the software responsible for managing the game. The software also controls the time for the answers.

6.4. Participants

- a. A team consists of up to three (3) participants who meet the eligibility of the requirements. The minimum number of registered participants per team shall be two (2). The following conditions apply:
 1. Teams may play sparingly, with a minimum of two (2) players.
 2. Each team must designate a captain, who will be responsible for uploading the team registration documents and for all communication with the organizing committee of the game.
 3. Teams may have a professor tutor, who will be responsible for selecting and training the team, as well as enabling the team registration (according to the item 3.g).
- b. The players and fans are responsible for their conduct during the tournament. Any acts of dishonesty or that are inconsistent with the spirit of the competition, detected by

RockBowl IX LARMS 2022

officers of the game, imply exclusion of the dispute. Please see the section on ethics and conduct.

6.5. Time

- a. Delays of more than ten (10) minutes of the scheduled time will result in disqualification of the team.
- b. The qualifying rounds and the semifinals will have a maximum of twenty (20) questions of duration, with no interval (including general questions and bonus).
- c. The final round will have a maximum of forty (40) questions of duration (including general questions and bonus).
- d. The player will have five (5) seconds to begin to answer the general question after pressing the buzzer.
- e. The team will have 25 (twenty-five) seconds to begin to answer the bonus question.
- f. The duration of the round can be extended in case of a tie, as the following:
 1. There will be an extension of three (3) general questions. Bonus questions will not be used in overtime.
 2. If the game remains tied after the three (3) extension questions, the moderator will continue asking questions until the tie ceases.

6.6. Questions

- a. Each game can have two (2) types of question: general questions (item 6.7), and bonus questions (item 6.8). In the rounds where bonus questions are applicable, the team receives the bonus question whenever a general question is answered correctly.
- b. In round of eight (8) teams, there will be seven (7) general questions and no bonus questions. The semi-finals will have nine (9) general questions and no bonus questions. The final will have nine (9) general questions and nine (9) bonus questions each.
- c. If a qualifying game is necessary according to item 4.d., its rounds will consist of the same number of general and bonus questions present in the round of eight (8) teams (item 4.a).
- d. The questions are selected from a previously created database.
- e. There will be no questions involving calculations.
- f. The questions aim to explore general knowledge in rock mechanics and the like, as well as knowledge of geotechnical community applied to rocks. The questions may include history of the rock mechanics, general affairs, current events, technical questions and troubleshooting.
- g. List of some suggested topics as a source of questions (not all included, also check other sources):
 1. Technical material: technical literature on rock mechanics fundamentals, rock mechanics applied to geology engineering, civil works, mining and petroleum geomechanics, which encompass the following topics:
 - i. Mechanical behavior

RockBowl IX LARMS 2022

- ii. Field tests
 - iii. Laboratory tests
 - iv. Slope stability
 - v. Underground excavations
 - vi. Characterization and classification
 - vii. Geology
 - viii. Geomechanical modeling
 - ix. Rock physics
 - x. Drilling geomechanics
 - xi. Reservoir geomechanics
 - xii. Mining
2. Non-technical material: the ISRM, general affairs, history, current affairs, statistics, evolution and application of rock mechanics over time in various civilizations, current events.

6.7. General questions

- a. The number of general questions for each round is defined in items 6.6.b and 6.6.c.
- b. The player can trigger the buzzer to answer the question at any time after the moderator has started the question. Any form of communication between team players or the audience during the general questions is **prohibited**. Violation of communication rule implies the loss of the right to answer the question. Repeated violations may result in disqualification of the team, as of Ethics and Conduct item.
- c. Team members should not communicate with each other even if the question is being answered by the opposing team.
- d. Once the player presses the buzzer, the game system will report the name of the player so that he/she can answer it. If the player starts the answer before being recognized by the system, he/she may lose the right to answer and this right passes to the other team.
- e. If a player presses the buzzer before the moderator finishes the question reading, this reading stops and the player must start the answer. If the player does not get the answer, the right to answer goes to the opposing team and the moderator reads the question again.
- f. The player has five (5) seconds to give the answer after the activation of the buzzer is recognized. An answer initiated after the system informs the timeout will not be considered.
- g. Each general question is worth ten (10) points.
- h. If there is no activation of the buzzer after the question reading ends, the moderator shall read the next question.
- i. The general question counts points for the award of the best player.

RockBowl IX LARMS 2022

6.8. Bonus questions

- a. The number of bonus questions for each round is defined in items 6.6.b and 6.6.c.
- b. Team members can communicate during the answer period of bonus questions.
- c. Only one player can give the answer agreed by the team.
- d. The team has twenty-five (25) seconds to start the answer after the completion of the question reading by the moderator. If the team requests that the question be repeated, time continues counting. The answer must be initiated no later than twenty-five (25) seconds after the end of the question reading.
- e. Each bonus question is worth twenty (20) points.
- f. If the team misses or does not answer the bonus question, it does not pass to the opposing team.
- g. The bonus question does not count for the best player award.

6.9. Correct answers

- a. Only the first answer given by a player will be accepted.
- b. If a question requires multiple answers, they will be accepted in any order. If either party is wrong, the answer will be given as wrong.
- c. If in doubt about the validity of the answer, the moderator will ask the analysis of the judges, whose decision will be unquestionable.

6.10. Ethics and conduct

- a. All players, institutional representatives (private or governmental) and other people associated with a team, are subject to the code of conduct and behavior in a responsible and ethical manner. This includes:
 1. Treat all participants, organizers and the public with good manners;
 2. Not receive or give unlawful "assistance";
 3. Do not try to fool teammates and officials of the game;
 4. Abide by all decisions of the tournament officials;
 5. Not be an accomplice of another person to "change" the outcome of the game;
 6. Promptly report any violations of conduct to tournament officials.
- b. Teams are prohibited of making an occasion for marketing during the event (**).
- c. Any manifestation with nature other than the game purpose such as political, religious and ideological are strictly prohibited, and the person who make it will be requested to leave the tournament.
- d. If any player makes a manifestation as per item 6.10.c, the team will be disqualified.
- e. Any official tournament may denounce the participants and fans of the game in the case of unsuitable behavior during the tournament. The misconduct includes

RockBowl IX LARMS 2022

inadequate behavior, unethical behavior or any violation of the code of conduct. Tournament officials may interpret these categories at their discretion.

- f. The major committed and / or repeated infractions may result in expulsion of an individual and / or disqualification of a team at the discretion of tournament officials.

**It is understood as an occasion for marketing an action that could be judged as looking for immediate advantages and opportunities for other brands that are not sponsors of the event.